

Lightning Atlantic Coast Championship (7/27/2017)

Sailing Instructions

July 29-30, 2017 Malletts Bay Boat Club, Colchester, Vermont, USA

1. Rules

The regatta will be governed by the Racing Rules of Sailing (RRS), the prescriptions of the United States Sailing Association (US Sailing), the rules of the International Lightning Class Association (ILCA), the Notice of Race, and these Sailing Instructions.

2. Notices to Competitors

Notices to competitors will be posted on the official notice board located on the North side of the ground floor of the MBBC Clubhouse.

3. Changes in Sailing Instructions

Any change in the sailing instructions will be posted before 0930 on the day it will take effect, except that any change in the schedule of races will be posted before 2000 on the day before it will take effect.

4. Signals Made Ashore

- 4.1 Signals made ashore will be displayed from MBBC Flag Pole.
- 4.2 When Pennant AP is displayed ashore, '1 minute' is replaced with 'not less than 60 minutes' in Race Signal AP.
- 4.3 When Code Flag I is displayed ashore, all Races will be sailed in the Inner Malletts Bay.

5. Schedule of Races:

29th (Saturday)	0800-0900 Registration 0900 Competitors Meeting 0930 All boats must be launched (Harbor Start) 1100 First Race 1800 Dinner
30th (Sunday)	0830 Harbor Start 1000 First Start Sunday Awards at MBBC immediately after sailing

- 5.1 The number of races shall be a minimum of three and a maximum of five, weather conditions permitting. Three races constitutes a series. No warning signal shall be made after 1500 Sunday, July 30, 2017
- 5.2 The finish boat will display Code Flag H when the last race of the day has been completed.

6. Racing Area

- 6.1 The primary racing area will be the Outer Malletts Bay, 3+ miles from the Club. The secondary racing area will be the Inner Bay, 1 mile from the Club.
- 6.2 If races are to be sailed in the Inner Bay, Code Flag "I" will be displayed ashore.

7. Courses

- 7.1 The diagrams shows the courses, the order in which marks are to be passed, and the side on which each mark is to be left.
- 7.2 There are 2 courses.

Windward Leeward (2WL)

The legs will be approximately 1.25 to 2 statute miles. There will be a weather mark and an off-set mark approximately 15 boat lengths away, both marks will be rounded to port. The leeward mark will be a gate with two marks approximately 8-10 boat lengths apart. A boat must pass between the marks and can round either mark to go upwind. The finish line will be between the Committee Boat and the weather mark (if finished to weather) or between the gates in the event of a shortened course.

Windward Leeward - Triangle (ΔWL)

The windward leg will be approximately 1.25 to 2 statute miles. Marks will be rounded to port. The finish line will be between the Committee Boat and the weather mark.

- 7.3 No later than the Warning Signal, the Race Committee boat will display the approximate compass bearing and range, in statute miles, from the starting line to the first mark.

8. Marks

- 8.1 All marks will be either orange or yellow shapes.
- 8.2 All Marks of the course shall be rounded to port, except the starboard leeward gate mark shall be rounded to starboard (the outside of the course). In the event that one of the gate marks is missing, the remaining mark will be rounded to port.

9. The Start

- 9.1 Races will be started in accordance with RRS 26
- 9.2 The start line is between the orange flag on the boat at the starboard end of the line and the windward side of the Weather Mark on the port end of the line.
- 9.3 Recalls - After the starting signal, the race committee intends to announce the sail and/or bow number of the recalled boat(s) on VHF channel 72. The following shall not be grounds for granting redress. This changes RRS 62.1(a).
 - (a) Failure of a boat to hear the recall broadcast.
 - (b) A boat's position in the sequence of broadcast numbers.
 - (c) Failure of the race committee to broadcast any numbers.

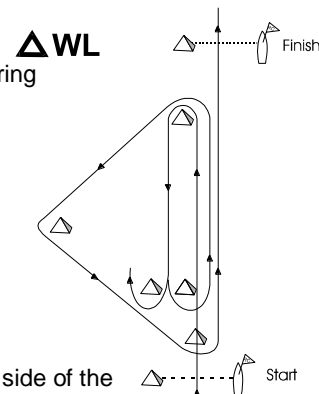
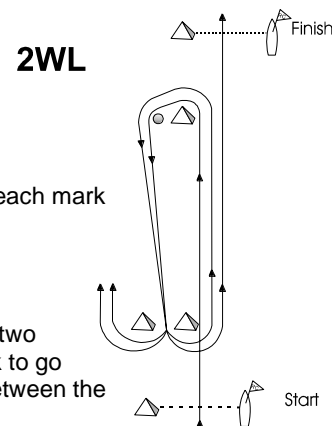

10. Change Of Course

A change of course will be signaled in accordance with RRS 33. Any mark to be rounded after rounding the new mark may be relocated to maintain the original course configuration..

11. The Finish

The finishing line will be between the orange flag on the boat at the starboard end of the line and the leeward side of the Weather Mark on the port end of the line.

12. Alternate Penalties

The two turns penalty will apply with the additional provision that when an infringing boat has its spinnaker drawing at the time of the infringement, drops it completely below the gooseneck while taking her penalty, and resets it immediately and has it drawing after the penalty; the penalty is a one turn penalty. This modifies RRS 44.1

13. Propulsion:

On a free leg of the course, when surfing (rapid accelerating down the leeward side of a wave) or planing is possible, the boat's crew may, in order to initiate surfing or planing, pump the sheet, but not the guy controlling any sail, but only once for each wave or gust of wind. When the mainsail is pumped, only that part of the sheet between the crew member handling the sheet and the first block on the boom shall be used. This modifies RRS 42.3 (c).

14. Abandonment and Time Limit

14.1 Time limit shall be three and one-half (3-1/2) hours. If one boat finishes within this limit, all must be timed

14.2 The Race Committee may abandon any race it judges not to be a fair test of sailing skill.

15. Measurement and Equipment

Each competitor is responsible for ensuring their equipment is in compliance with the ILCA rules.

16. Protests

16.1 Protests should be lodged with the protest secretary on board the committee boat within 1 hour of the time the Race Committee Boat docks. The Race Committee will post the docking (beginning of protest) time on the official notice board as soon as practical after docking. Forms are available from the protest secretary.

16.2 Protests will be heard in the approximate order of receipt. The time and place of protest hearings will be posted within 30 minutes after the end of the protest time. This is the notice required by RRS 63.2.

17. Scoring

17.1 Each boat's total score will be the sum of her scores for all races.

17.2 Boats that tie in a single race shall score points equal to the best position involved. The position(s) immediately after shall remain vacant (if two boats tie for first place, both are scored 1 point, and the next boat to finish scores 3 points). This paragraph modifies RRS A7.

18. Support Boats

Team leaders, coaches, and other support personnel shall stay outside the racing area (defined as 100 meters outside the lay lines of the course, including the start area) from the first warning signal of the day until the last boat has finished the last race of each day, unless otherwise designated in the Sailing Instructions. Individual competitors may not use a support boat(s) at any time during the Regatta except as provided by the Organizing Authority. The penalty for failing to comply with these requirements may be the disqualification of all yachts associated with the infringing support personnel.

19. Radio Communications

19.1 Except when notifying the Race Committee of her intent to withdraw from the race as per SI Rule 18.2, a boat shall neither make radio transmissions nor receive radio communications not available to all boats. This restriction also applies to mobile telephones.

19.2 The race committee intends to use VHF marine radio frequency Channel 72 to broadcast courtesy information to competitors, including OCS hails after starts.

19.3 VHF radios with GPS features that are carried aboard during the regatta shall not be used while racing, unless otherwise permitted by the Notice of Race or these Sailing Instructions.

20. Replacement of Crew or Equipment

20.1 Substitution of crew will not be allowed without prior approval of the Race Committee.

20.2 Substitution of Class specified/measured, damaged or lost equipment shall not be allowed without prior authorization by the Race Committee.

21. Haul-Out Restrictions

All boats must be in the water by 0930 July 29th, and remain in the water for the duration of the regatta except by written permission from the Principal Race Officer (PRO). All trailers will be stored off MBBC property.

22. Trophies

Trophies will be awarded to the top five skippers and crews. The Arnold Schwartz Perpetual Trophies will be awarded to the winning skipper.